



DGC-2020ES

Digital Genset Controller

Installation Instruction Manual



 **WARNING:** California's Proposition 65 requires special warnings for products that may contain chemicals known to the state of California to cause cancer, birth defects, or other reproductive harm. Please note that by posting this Proposition 65 warning, we are notifying you that one or more of the Proposition 65 listed chemicals may be present in products we sell to you. For more information about the specific chemicals found in this product, please visit <https://www.basler.com/Prop65>.

Preface

This instruction manual provides information about the installation of the DGC-2020ES Digital Genset Controller. To accomplish this, the following information is provided:

- Mounting
- Terminals and connectors
- Typical applications
- Power input
- Voltage and current sensing
- Speed signal inputs
- Specifications
- Maintenance and troubleshooting

Conventions Used in this Manual

Important safety and procedural information is emphasized and presented in this manual through Warning, Caution, and Note boxes. Each type is illustrated and defined as follows.

Warning!

Warning boxes call attention to conditions or actions that may cause personal injury or death.

Caution

Caution boxes call attention to operating conditions that may lead to equipment or property damage.

Note

Note boxes emphasize important information pertaining to Digital Genset Controller installation or operation.

DGC-2020ES Instruction Manual Catalog

Available instruction manuals for the DGC-2020ES are listed in Table 1.

Table 1. Instruction Manuals

Part Number	Description
9469200993	Quick Start
9469200994	Installation (this manual)
9469200995	Configuration
9469200996	Operation
9469200997	Accessories



12570 State Route 143
Highland IL 62249-1074 USA

www.basler.com

info@basler.com

Tel: +1 618.654.2341

Fax: +1 618.654.2351

© 2023 by Basler Electric

All rights reserved

First printing: April 2017

Warning!

READ THIS MANUAL. Read this manual before installing, operating, or maintaining the DGC-2020ES. Note all warnings, cautions, and notes in this manual as well as on the product. Keep this manual with the product for reference. Only qualified personnel should install, operate, or service this system. Failure to follow warning and cautionary labels may result in personal injury or property damage. Exercise caution at all times.

Caution

Installing previous versions of firmware may result in compatibility issues causing the inability to operate properly and may not have the enhancements and resolutions to issues that more recent versions provide. Basler Electric highly recommends using the latest version of firmware at all times. Using previous versions of firmware is at the user's risk and may void the warranty of the unit.

Basler Electric does not assume any responsibility to compliance or noncompliance with national code, local code, or any other applicable code. This manual serves as reference material that must be well understood prior to installation, operation, or maintenance.

For terms of service relating to this product and software, see the *Commercial Terms of Products and Services* document available at www.basler.com/terms.

This publication contains confidential information of Basler Electric Company, an Illinois corporation. It is loaned for confidential use, subject to return on request, and with the mutual understanding that it will not be used in any manner detrimental to the interests of Basler Electric Company and used strictly for the purpose intended.

It is not the intention of this manual to cover all details and variations in equipment, nor does this manual provide data for every possible contingency regarding installation or operation. The availability and design of all features and options are subject to modification without notice. Over time, improvements and revisions may be made to this publication. Before performing any of the following procedures, contact Basler Electric for the latest revision of this manual.

The English-language version of this manual serves as the only approved manual version.

Revision History

A historical summary of the changes made to this instruction manual is provided below. Revisions are listed in reverse chronological order.

Visit www.basler.com to download the latest hardware, firmware, and BESTCOMSP^{Plus}® revision histories.

Instruction Manual Revision History

Manual Revision and Date	Change
D, Jul-23	<ul style="list-style-type: none"> Added China RoHS in the <i>Specifications</i> chapter
C, Dec-21	<ul style="list-style-type: none"> Improved description of Emergency Stop input. Added UKCA compliance Removed CSA certification
B, Nov-19	<ul style="list-style-type: none"> Removed Rev Letter from all pages. Changed sequential numbering to sectional numbering. Moved Instruction Manual Revision History into Preface. Removed standalone Revision History chapter. Corrected Figures 3-3 and 3-4. Added GEN VN connection.
A1, Apr-19	<ul style="list-style-type: none"> Updated Proposition 65 statement
A, Sep-18	<ul style="list-style-type: none"> Updated <i>Revision History</i> chapter
—, Apr-17	<ul style="list-style-type: none"> Initial release



Contents

Mounting.....	1-1
Terminals and Connectors.....	2-1
Typical Connections.....	3-1
Power Input.....	4-1
Voltage and Current Sensing.....	5-1
Speed Signal Inputs.....	6-1
Specifications.....	7-1
Maintenance.....	8-1
Troubleshooting.....	9-1



1 • Mounting

DGC-2020ES controllers are delivered in sturdy cartons to prevent shipping damage. Upon receipt of a unit, check the part number against the requisition and packing list for agreement. Inspect for damage, and if there is evidence of such, immediately file a claim with the carrier and notify the Basler Electric regional sales office or your sales representative.

If the device is not installed immediately, store it in the original shipping package in a moisture- and dust-free environment.

Hardware

The front panel is resistant to moisture, salt fog, humidity, dust, dirt, and chemical contaminants. DGC-2020ES controllers are mounted using the four permanently attached 10-24 studs. The torque applied to the mounting hardware should not exceed 20 inch-pounds (2.2 newton meters).

Dimensions

Panel cutting and drilling dimensions are shown in Figure 1-1. Overall dimensions are shown in Figure 1-2. All dimensions are shown in inches with millimeters in parenthesis.

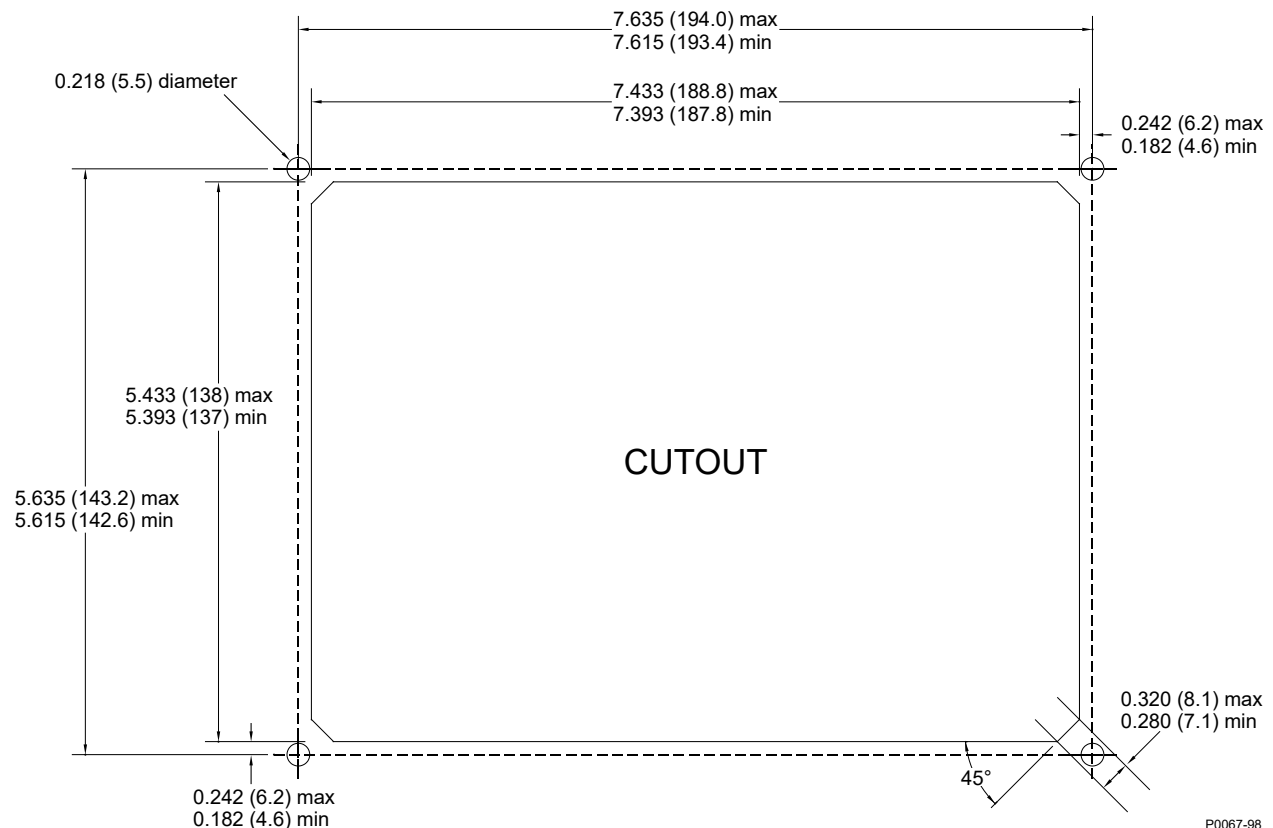

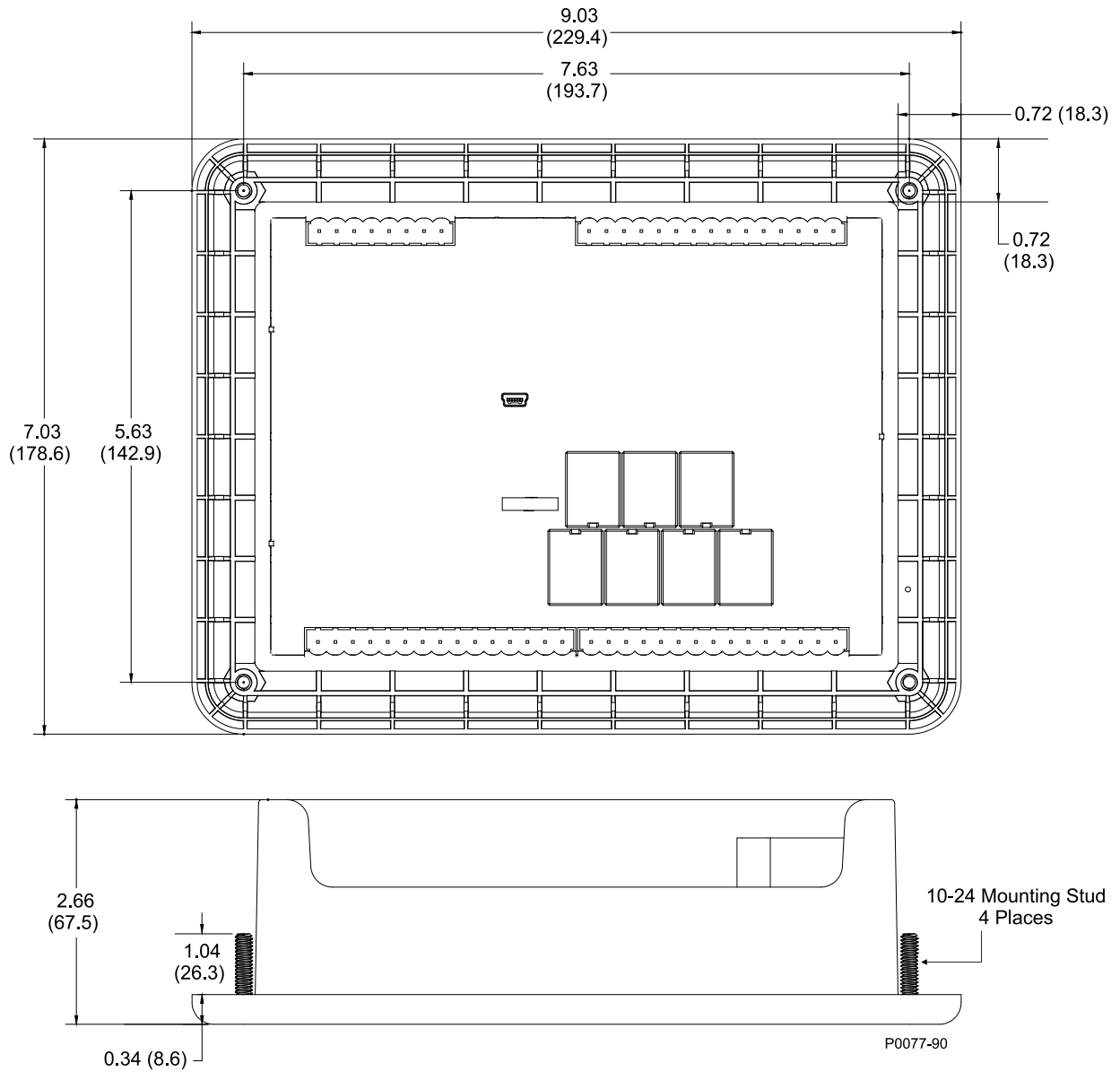

Figure 1-2. Overall Dimensions

2 • Terminals and Connectors

All DGC-2020ES terminals and connectors are located on the rear panel. DGC-2020ES terminals consist of a mini-B USB socket and plug-in connectors with spring clamp terminals.

Figure 2-1 illustrates the rear panel terminals. Locator letters in the illustration correspond to the terminal block and connector descriptions in Table 2-1.

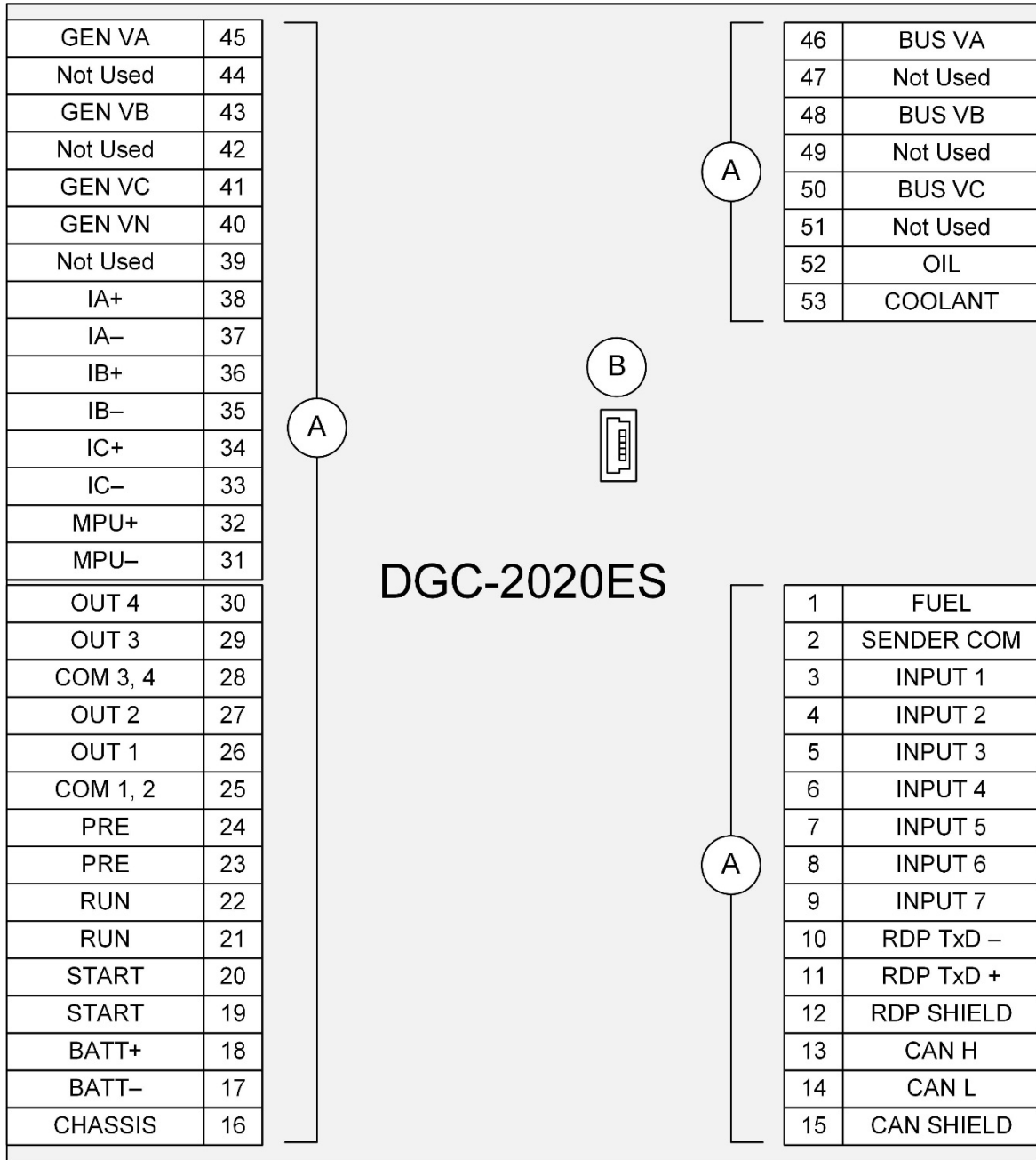

Figure 2-1. Rear Panel

Table 2-1. Rear Panel Terminal and Connector Descriptions

Locator	Description
A	The majority of external, DGC-2020ES wiring is terminated at 8- or 15-position connectors with spring clamp terminals. These connectors plug into headers on the DGC-2020ES. The connectors and headers have a dovetailed edge that ensures proper connector orientation. Each connector and header is uniquely keyed to ensure that a connector mates only with the correct header. Spring clamp terminals accept a maximum wire size of 12 AWG.
B	The mini-B USB socket mates with a standard USB cable and is used with a PC running BESTCOMSPi ^{us} ® software for local communication with the DGC-2020ES.

Connections

DGC-2020ES connections are dependent on the application. Incorrect wiring may result in damage to the controller.

Note

Be sure that the DGC-2020ES is hard-wired to earth ground with no smaller than 12 AWG copper wire attached to the chassis ground terminal (terminal 16) on the rear of the controller.

Operating power from the battery must be of the correct polarity. Although reverse polarity will not cause damage, the DGC-2020ES will not operate.

For the DGC-2020ES to correctly meter power factor, the generator must be rotating clockwise (A-B-C).

The DGC-2020ES terminals are grouped by function and include operating power, generator current sensing, generator voltage sensing, bus voltage sensing, analog engine sender inputs, magnetic pickup input, contact sensing inputs, output contacts, USB interface, CAN interface, and Remote Display Panel connections.

DGC-2020ES terminal groups are described in the following paragraphs.

Operating Power

The DGC-2020ES operating power input accepts either 12 Vdc or 24 Vdc and tolerates voltage over the range of 6 to 32 Vdc. Operating power must be of the correct polarity. Although reverse polarity will not cause damage, the DGC-2020ES will not operate. Operating power terminals are listed in Table 2-2.

It is recommended that a fuse be added for additional protection for the wiring to the battery input of the DGC-2020ES. A fuse helps prevent wire damage and nuisance trips due to initial power supply inrush current. To follow UL guidelines, a 5 A maximum, 32 Vdc supplementary fuse must be implemented in the battery input circuit to the DGC-2020ES

Table 2-2. Operating Power Terminals

Terminal	Description
16 (CHASSIS)	Chassis ground connection
17 (BATT-)	Negative side of operating power input
18 (BATT+)	Positive side of operating power input

Generator Current Sensing

The DGC-2020ES has sensing inputs for A-phase, B-phase, and C-phase generator current. A DGC-2020ES with a style number of 1xx has a 1 Aac nominal current sensing and a DGC-2020ES with a style number of 5xx indicates 5 Aac nominal current sensing. Generator current sensing terminals are listed in Table 2-3.

Table 2-3. Generator Current Sensing Terminals

Terminals	Description
37 (IA-)	A-phase current sensing input
38 (IA+)	
35 (IB-)	B-phase current sensing input
36 (IB+)	
33 (IC-)	C-phase current sensing input
34 (IC+)	

Note

Unused current sensing inputs should be shorted to minimize noise pickup.

Caution

Generator current sensing terminals 37 (IA-), 35 (IB-), and 33 (IC-) must be terminated to ground for proper operation.

Generator Voltage Sensing

The DGC-2020ES accepts either line-to-line or line-to-neutral generator sensing voltage over the range of 12 to 576 volts, rms line-to-line. Generator voltage sensing terminals are listed in Table 2-4.

Table 2-4. Generator Voltage Sensing Terminals

Terminal	Description
40 (GEN VN)	Neutral generator voltage sensing input
41 (GEN VC)	C-phase generator voltage sensing input
43 (GEN VB)	B-phase generator voltage sensing input
45 (GEN VA)	A-phase generator voltage sensing input

Installation in an Ungrounded System Application

When the DGC-2020ES is controlling equipment that is part of an ungrounded system, it is recommended that potential transformers be employed on the voltage sensing inputs to provide full isolation between the DGC-2020ES and monitored voltage phases.

Bus Voltage Sensing

Sensing of bus voltage enables the DGC-2020ES to detect failures of the mains (utility). The DGC-2020ES senses A-phase, B-phase, and C-phase bus voltage. Bus voltage sensing terminals are listed in Table 2-5.

Table 2-5. Bus Voltage Sensing Terminals

Terminal	Description
46 (BUS VA)	A-phase bus voltage sensing input
48 (BUS VB)	B-phase bus voltage sensing input
50 (BUS VC)	C-phase bus voltage sensing input

Installation in an Ungrounded System Application

When the DGC-2020ES is controlling equipment that is part of an ungrounded system, it is recommended that potential transformers be employed on the voltage sensing inputs to provide full isolation between the DGC-2020ES and monitored voltage phases.

Analog Engine Sender Inputs

Inputs are provided for oil pressure, fuel level, and coolant temperature senders. For a listing of oil pressure, fuel level, and coolant temperature senders that are compatible with the DGC-2020ES, refer to the *Engine Sender Inputs* chapter in the *Configuration* manual. Analog engine sender input terminals are listed in Table 2-6.

Table 2-6. Sender Input Terminals

Terminal	Description
1 (FUEL)	Fuel level sender input
2 (SENDER COM)	Sender return terminal
52 (OIL)	Oil pressure sender input
53 (COOLANT)	Coolant temperature sender input

Magnetic Pickup Input

The magnetic pickup input accepts a speed signal over the range of 3 to 35 volts peak and 32 to 10,000 hertz. Magnetic pickup input terminals are listed in Table 2-7.

Table 2-7. Magnetic Pickup Input Terminals

Terminals	Description
31 (MPU-)	Magnetic pickup return input
32 (MPU+)	Magnetic pickup positive input

Contact Sensing Inputs

Contact sensing inputs consist of seven programmable inputs. The programmable inputs accept normally open, dry contacts. Terminal 17 (BATT-) serves as the common return line for the programmable inputs. While input 1 is programmed to recognize an emergency stop input by default, it can be programmed for any function. Information about configuring the programmable inputs is provided in the *Contact Inputs* chapter in the *Configuration* manual. Contact sensing input terminals are listed in Table 2-8.

Table 2-8. Contact Sensing Inputs

Terminal	Description
17 (BATT-)	Common return line for programmable contact inputs
3 (INPUT 1)	Programmable contact input 1 (ESTOP by default)
4 (INPUT 2)	Programmable contact input 2
5 (INPUT 3)	Programmable contact input 3

Terminal	Description
6 (INPUT 4)	Programmable contact input 4
7 (INPUT 5)	Programmable contact input 5
8 (INPUT 6)	Programmable contact input 6
9 (INPUT 7)	Programmable contact input 7

Emergency Stop Input

The emergency stop input is intended for use with a normally closed switch and recognizes an emergency stop input when the connection from terminal 3 (INPUT 1 by default) to ground is removed. While input 1 is programmed to recognize an emergency stop input by default, it can be programmed for any function.

Output Contacts

The DGC-2020ES has three sets of fixed-function output contacts: Pre, Start, and Run. The Pre contacts supply battery power to the engine glow plugs, the Start contacts supply power to the starter solenoid, and the Run contacts supply power to the fuel solenoid. Connections to the three sets of contacts are made at terminals 19 through 24. The Pre, Start, and Run relay terminals are listed in Table 2-9.

Table 2-9. Fixed-Function Output Contact Terminals

Terminal	Description
19 (START)	Start output contact (Start solenoid)
20 (START)	
21 (RUN)	Run output contact (Fuel solenoid)
22 (RUN)	
23 (PRE)	Pre-start output contact (Glow plugs)
24 (PRE)	

Four programmable output contacts are provided in two sets. Each set of two output contacts share a common terminal. Programmable output contact terminals are listed in Table 2-10.

Table 2-10. Programmable Output Contact Terminals

Terminal	Description
25 (COM 1, 2)	Common connection for outputs 1 and 2
26 (OUT 1)	Programmable output 1
27 (OUT 2)	Programmable output 2
28 (COM 3, 4)	Common connection for outputs 3 and 4
29 (OUT 3)	Programmable output 3
30 (OUT 4)	Programmable output 4

USB Interface

A mini-B USB socket enables local communication with a PC running BESTCOMSP^{Plus} software. The DGC-2020ES is connected to a PC using a standard USB cable equipped with a type A plug on one end (PC termination) and a mini-B plug on the other end (DGC-2020ES termination).

CAN Interface

These terminals provide communication using the SAE J1939 protocol or the *mtu* protocol and provide high-speed communication between the DGC-2020ES and an ECU on an electronically controlled engine. Connections between the ECU and DGC-2020ES should be made with twisted-pair, shielded cable. CAN interface terminals are listed in Table 2-11. For typical CAN connections, refer to the *Typical Connections* chapter.

Table 2-11. CAN Interface Terminals

Terminals	Description
13 (CAN H)	CAN high connection
14 (CAN L)	CAN low connection
15 (SHIELD)	CAN drain connection

Note

1. If the DGC-2020ES is providing one end of the J1939 bus, a 120 ohm, ½ watt terminating resistor should be installed across terminals 14 (CANL) and 13 (CANH).
2. If the DGC-2020ES is not providing one end of the J1939 bus, the stub connecting the DGC-2020ES to the bus should not exceed 914 mm (3 ft) in length.
3. The maximum bus length, not including stubs, is 40 m (131 ft).
4. The J1939 drain (shield) should be grounded at one point only. If grounded elsewhere, do not connect the drain to the DGC-2020ES

Optional Remote Display Panel Connections

Terminals are provided for connection with the optional Remote Display Panel. These terminals provide dc operating power to the Remote Display Panel and enable communication between the DGC-2020ES and Remote Display Panel. Twisted-pair conductors are recommended for connecting the communication terminals of the DGC-2020ES and Remote Display Panel. Communication may become unreliable if the connection wires exceed 1,219 m (4,000 ft). Table 2-12 lists the DGC-2020ES terminals that connect to the Remote Display Panel.

Table 2-12. Remote Display Panel Interface Terminals

Terminal	Description
10 (RDP TxD-)	Remote Display Panel terminal (TxD-)
11 (RDP TxD+)	Remote Display Panel terminal (TxD+)
17 (BATT-)	Remote Display Panel terminal DC COM (-)
18 (BATT+)	Remote Display Panel terminal 12/24 (+)

3 • Typical Connections

Typical connection diagrams are provided in this chapter as a guide when wiring the DGC-2020ES for communication, mechanical senders, contact inputs and outputs, sensing, and control power.

Connections for Typical Applications

Typical connections for applications using three-phase wye, three-phase delta, single-phase AB, and single-phase AC generator voltage sensing are shown on the following pages.

Figure 3-1 illustrates typical three-phase wye generator voltage sensing connections.

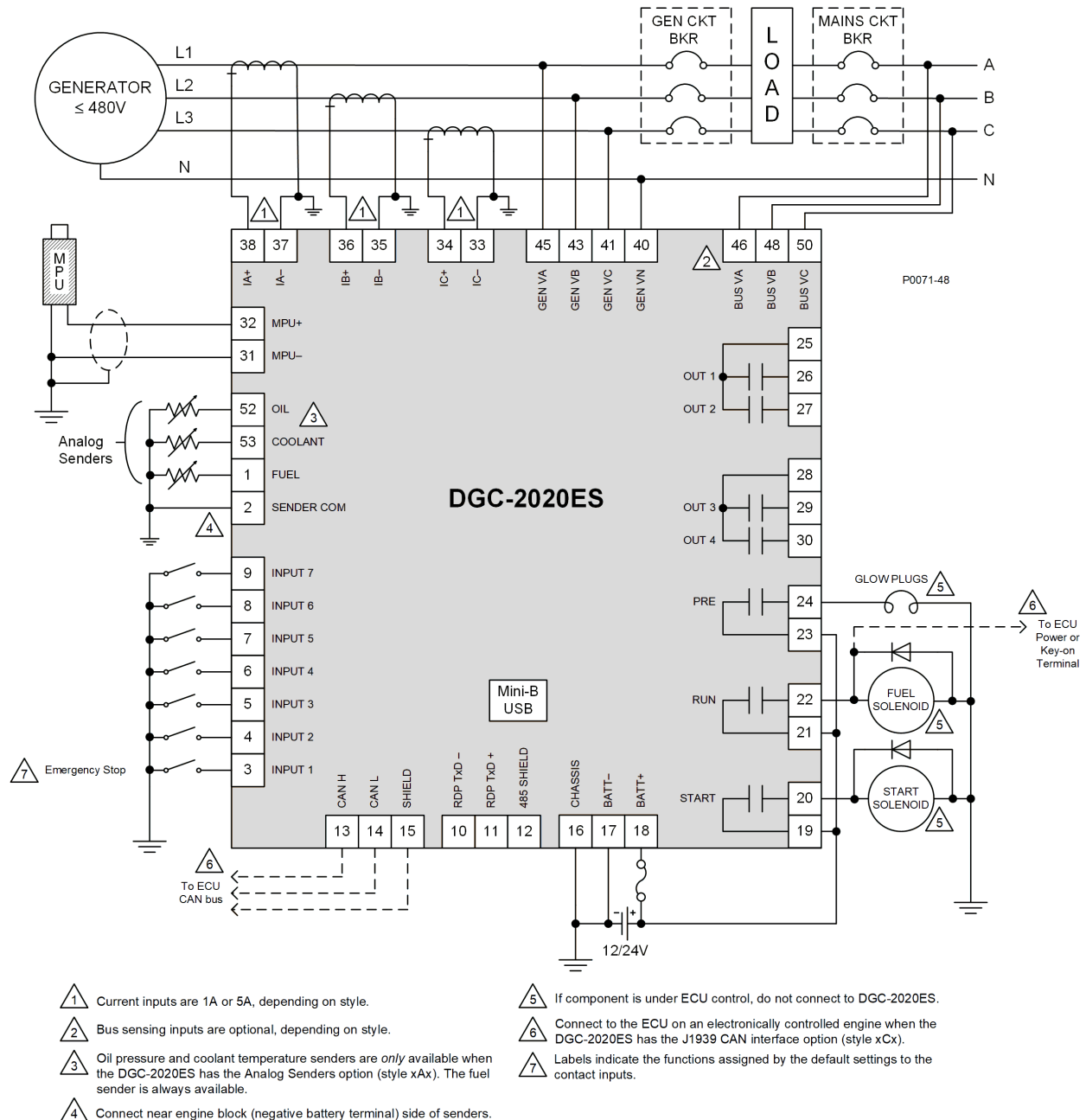

Figure 3-1. Three-Phase Wye Connections for Typical Applications

Figure 3-2 illustrates typical three-phase delta generator voltage sensing connections.

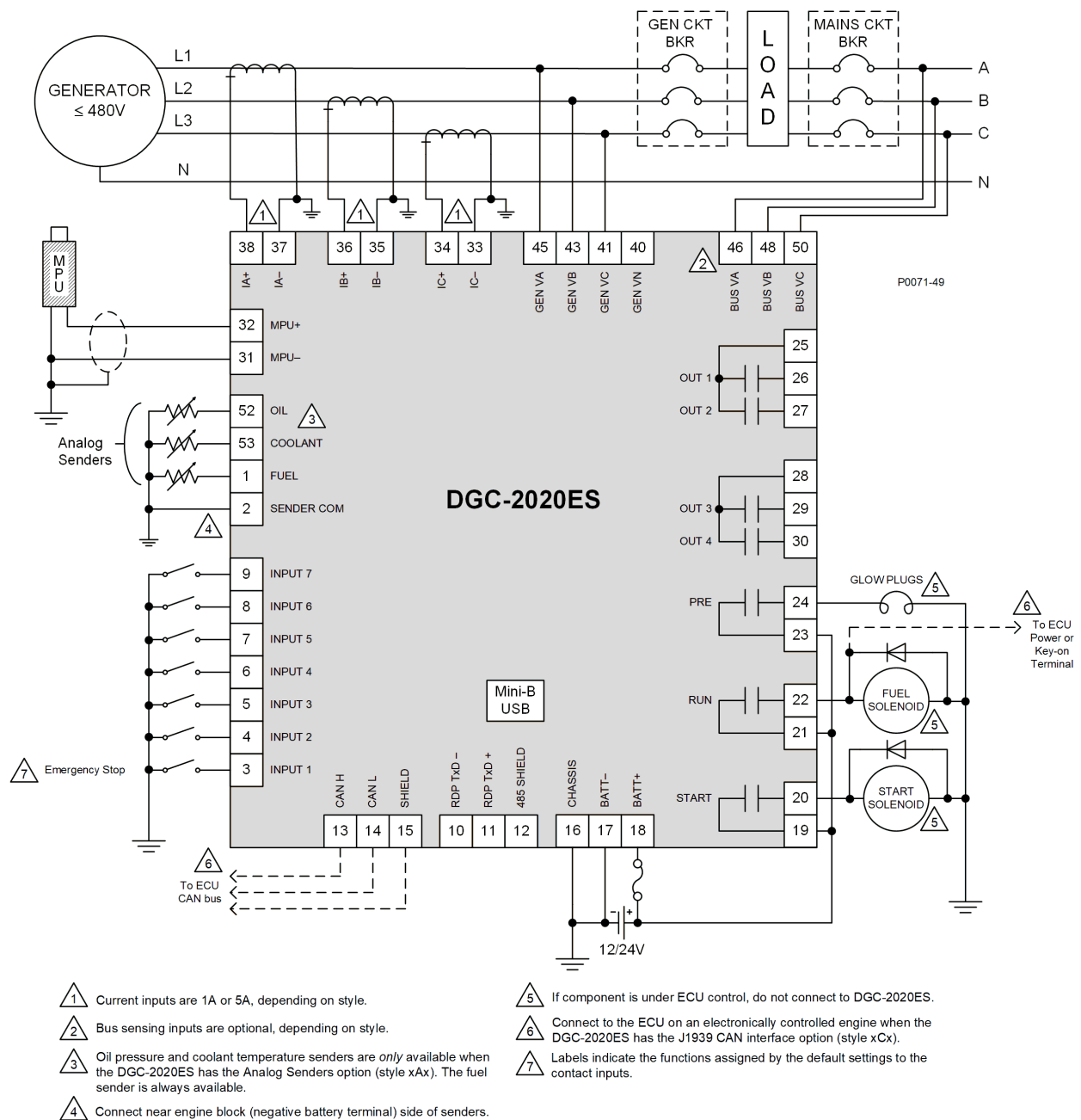

Figure 3-2. Three-Phase Delta Connections for Typical Applications

Figure 3-3 illustrates typical single-phase A-B generator voltage sensing connections.

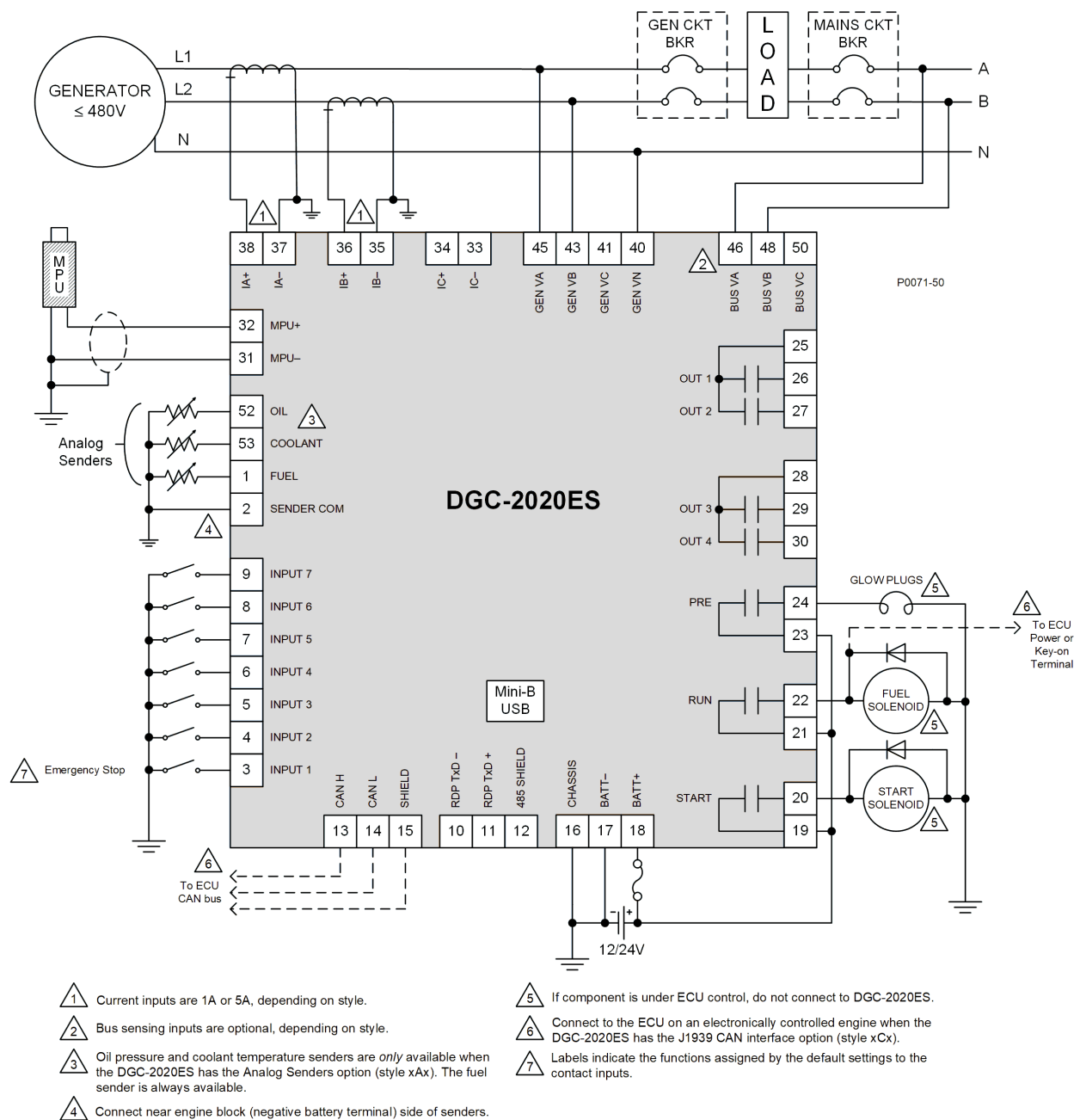
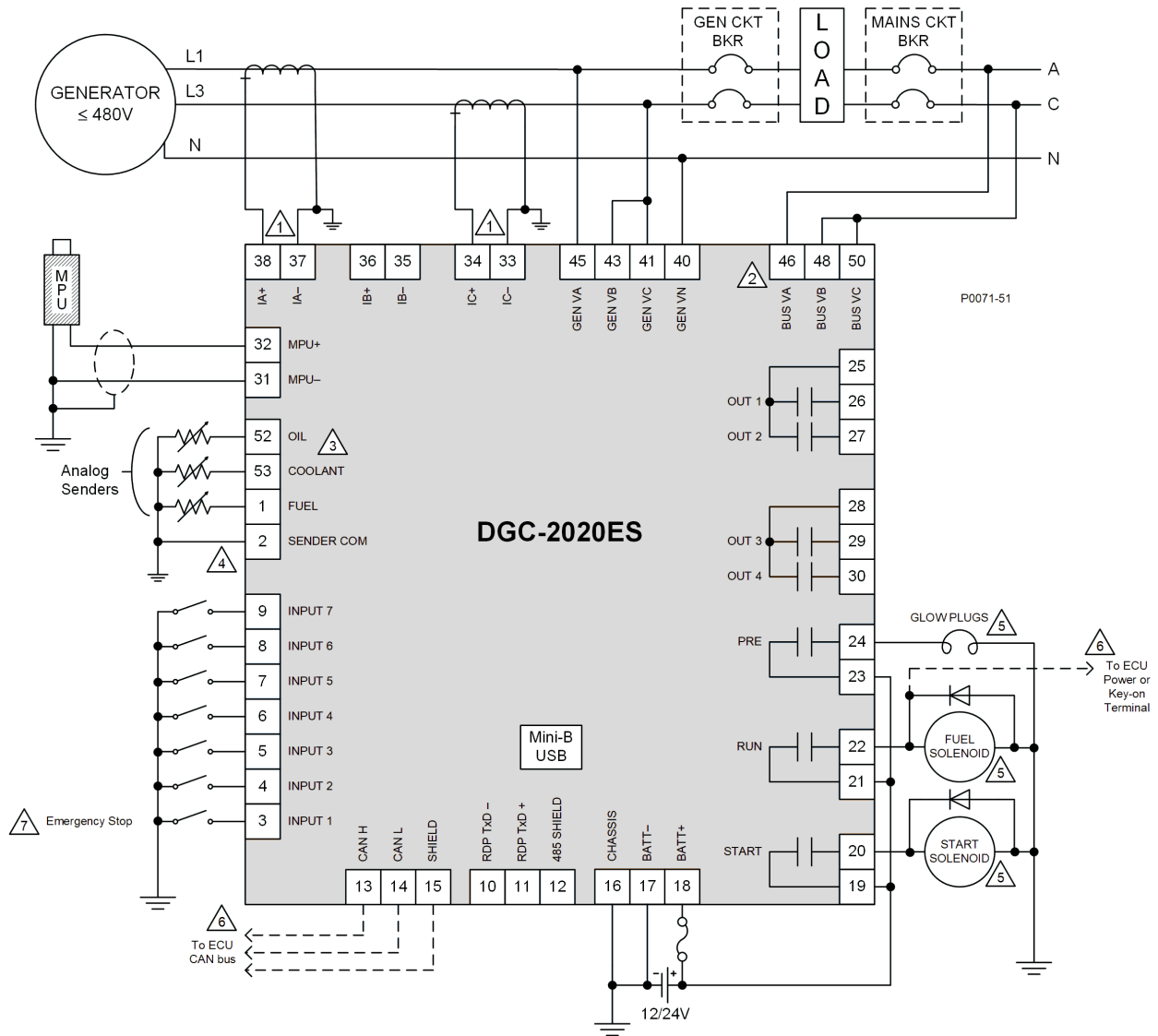

Figure 3-3. Single-Phase A-B Connections for Typical Applications

Figure 3-4 illustrates typical single-phase A-C generator voltage sensing connections.



- 1 Current inputs are 1A or 5A, depending on style.
- 2 Bus sensing inputs are optional, depending on style.
- 3 Oil pressure and coolant temperature senders are *only* available when the DGC-2020ES has the Analog Senders option (style xAx). The fuel sender is always available.
- 4 Connect near engine block (negative battery terminal) side of senders.
- 5 If component is under ECU control, do not connect to DGC-2020ES.
- 6 Connect to the ECU on an electronically controlled engine when the DGC-2020ES has the J1939 CAN interface option (style xCx).
- 7 Labels indicate the functions assigned by the default settings to the contact inputs.

Figure 3-4. Single-Phase A-C Connections for Typical Applications

CAN Connections

Typical CAN connections are shown in Figure 3-5 and Figure 3-6.

Note

1. If the DGC-2020ES is providing one end of the J1939 bus, a 120 ohm, ½ watt terminating resistor should be installed across terminals 14 (CANL) and 13 (CANH).
2. If the DGC-2020ES is not providing one end of the J1939 bus, the stub connecting the DGC-2020ES to the bus should not exceed 914 mm (3 ft) in length.
3. The maximum bus length, not including stubs, is 40 m (131 ft).
4. The J1939 drain (shield) should be grounded at one point only. If grounded elsewhere, do not connect the drain to the DGC-2020ES.

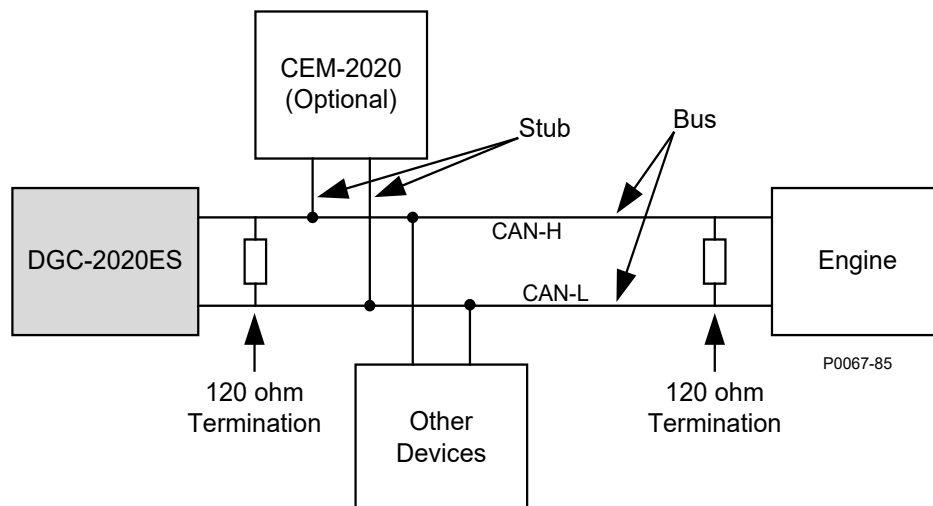

Figure 3-5. CAN Interface with DGC-2020ES Providing One End of the Bus

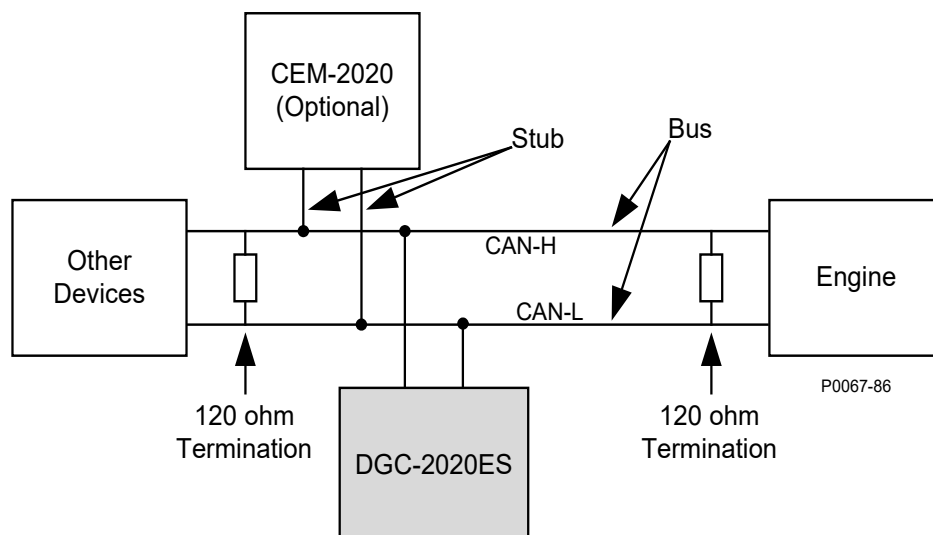
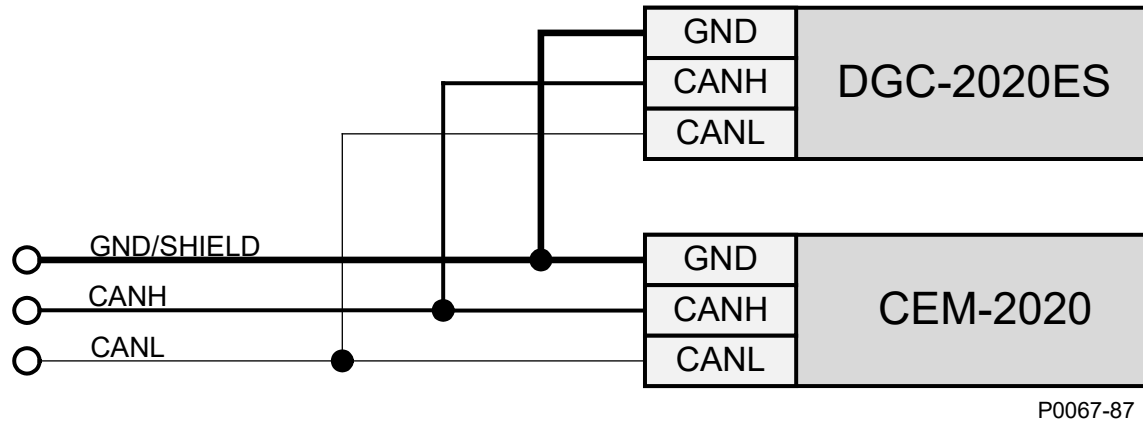

Figure 3-6. CAN Interface with Other Devices

CEM-2020 Connections

The CEM-2020 (Contact Expansion Module) is an optional module that may be installed with the DGC-2020ES. It is a remote auxiliary device that provides additional contact inputs and outputs for the DGC-2020ES. This module interfaces to the DGC-2020ES via CAN, thus the CAN terminals are the only common connections (Figure 3-7) between the DGC-2020ES and CEM-2020. Refer to the *CEM-2020* chapter for more information.

Refer to *Terminals and Connectors* for details on DGC-2020ES CAN connections.



P0067-87

Figure 3-7. DGC-2020ES and CEM-2020 CAN Connections

Installation for CE Systems

For CE compliant systems, it may be required to route ac voltage and current sensing wires separately from other wires.

Installation in an Ungrounded System Application

When the DGC-2020ES is controlling equipment that is part of an ungrounded system, it is recommended that potential transformers be employed on the voltage sensing inputs to provide full isolation between the DGC-2020ES and monitored voltage phases.

4 • Power Input

Control power for the DGC-2020ES is typically supplied by the genset starter battery. Power from the battery is supplied to an internal power supply that provides power for DGC-2020ES logic, protection, and control functions.

Nominal Voltage Input and Acceptable Range of Input Voltage

A nominal voltage of 12 or 24 Vdc within a range of 6 to 32 Vdc is accepted. Control power must be of the correct polarity. Although reverse polarity will not cause damage, the DGC-2020ES will not operate.

Terminal Assignments

Input power is applied to terminals 18 (BATT+), 17 (BATT-), and 16 (CHASSIS).

Power Consumption

The amount of power consumed by the DGC-2020ES varies based on the selected mode. The power saving Sleep mode consumes 4.5 W with all relays de-energized. The Normal Operational Mode consumes 6.5 watts in Run mode with the LCD heater off and 3 relays energized. The Maximum Operational Mode consumes 14 watts in Run mode with the LCD heater on and 7 relays energized.

Battery Ride-Through Capability

Starting at 10 Vdc, withstands cranking ride-through down to 0 Vdc for 50 milliseconds.

Fuse Protection

To follow UL guidelines, a 5 A maximum, 32 Vdc supplementary fuse must be implemented in the battery input circuit to the DGC-2020ES.



5 • Voltage and Current Sensing

The DGC-2020ES senses generator voltage, generator current, and bus voltage through dedicated, isolated inputs.

Generator Voltage

The DGC-2020ES accepts either line-to-line or line-to-neutral generator sensing voltage over the range of 12 to 576 volts, rms line-to-line. Single-phase generator voltage is sensed across phases A and B. Generator voltage sensing terminals are listed in Table 5-1.

Table 5-1. Generator Voltage Sensing Terminals

Terminal	Description
40 (GEN VN)	Neutral generator voltage sensing input
41 (GEN VC)	C-phase generator voltage sensing input
43 (GEN VB)	B-phase generator voltage sensing input
45 (GEN VA)	A-phase generator voltage sensing input

Bus Voltage

Bus sensing over the range of 12 to 576 volts rms line-to-line is accepted by the DGC-2020ES. Sensing of bus voltage enables the DGC-2020ES to detect failures of the mains (utility). Controllers with style number xx2 measure bus voltage sensing to perform automatic mains failure transfers. Single-phase bus voltage is sensed across phases A and B. Bus voltage sensing terminals are listed in Table 5-2.

Table 5-2. Bus Voltage Sensing Terminals

Terminal	Description
46 (BUS VA)	A-phase bus voltage sensing input
48 (BUS VB)	B-phase bus voltage sensing input
50 (BUS VC)	C-phase bus voltage sensing input

Generator Current

The DGC-2020ES has sensing inputs for A-phase, B-phase, and C-phase generator current. Depending on the style number, a DGC-2020ES has a nominal sensing current rating of 1 Aac or 5 Aac. A style number of 1xx indicates 1 Aac nominal current sensing and a style number of 5xx indicates 5 Aac nominal current sensing. Generator current sensing terminals are listed in Table 5-3.

Table 5-3. Generator Current Sensing Terminals

Terminal	Description
38 (IA+)	A-phase generator current sensing input
37 (IA-)	
36 (IB+)	B-phase generator current sensing input
35 (IB-)	
34 (IC+)	C-phase generator current sensing input
33 (IC-)	

Note

Unused current sensing inputs should be shorted to minimize noise pickup.

Caution

Generator current sensing terminals 37 (IA-), 35 (IB-), and 33 (IC-) must be terminated to ground for proper operation.

6 • Speed Signal Inputs

The DGC-2020ES uses signals from the generator voltage sensing inputs and magnetic pickup (MPU) input to detect machine speed.

Magnetic Pickup

Voltage supplied by a magnetic pickup is scaled and conditioned for use by the internal circuitry as a speed signal source. The MPU input accepts a signal over the range of 3 to 35 volts peak and 32 to 10,000 hertz.

Terminals

Magnetic pickup connections are provided at terminals 31 (+) and 32 (-).

Generator Sensing Voltage

The generator voltage sensed by the DGC-2020ES is used to measure frequency and can be used to measure machine speed.

Terminals

Sensing voltage is applied to terminals 45 (A-phase), 43 (B-phase).



7 • Specifications

DGC-2020ES electrical and physical characteristics are listed in the following paragraphs.

Control Power

Nominal	12 or 24 Vdc
Range	6 to 32 Vdc
Terminals.....	18 (+), 17 (-), 16 (chassis ground)

Power Consumption

Sleep Mode	4.5 W - LCD heater off, all relays de-energized
Normal Operational Mode	6.5 W - Run mode, LCD heater off, 3 relays energized
Maximum Operational Mode	14 W - Run mode, LCD heater on, 7 relays energized

Battery Ride Through

Starting at 10 Vdc, withstands cranking ride-through down to 0 Vdc for 50 ms

Current Sensing

Burden	1 VA
Terminals.....	38, 37 (A-phase)
	36, 35 (B-phase)
	34, 33 (C-phase)

1 Aac Current Sensing

Continuous Rating.....	0.02 to 1.0 Aac
1 Second Rating.....	5 Aac
0.050 Second Rating.....	10 Aac

5 Aac Current Sensing

Continuous Rating.....	0.1 to 5.0 Aac
1 Second Rating.....	25 Aac
0.050 Second Rating.....	50 Aac

Voltage Sensing

Range.....	12 to 576 V rms, line-to-line
Frequency	50/60 Hz
Frequency Range.....	10 to 72 Hz
Burden	1 VA
1 Second Rating.....	720 V rms

Generator Sensing

Configuration.....	Line-to-line or line-to-neutral
Generator Sensing Terminals	45 (A-phase)
	43 (B-phase)
	41 (C-phase)
	40 (Neutral)

Bus Sensing

Configuration	Line-to-line
Bus Sensing Terminals	46 (A-phase)
(Optional with style number xx2)	48 (B-phase)
	50 (C-phase)

Contact Sensing

Contact sensing inputs include seven programmable inputs. All inputs accept dry contacts.

Time from a DGC-2020ES input application to:

- Shutdown the generator via an alarm = 490 ms max
- Close a relay on board the DGC-2020ES = 215 ms max
- Close a relay on board the CEM-2020 = 400 ms max

Notes

A contact input is true (on) if the input is connected to battery ground with a resistance of less than 240 ohms.

The maximum length of wire that can be accommodated depends on the resistance of the wire, and the resistance of the contacts of the device driving the input at the far end of the wire.

The maximum wire length can be calculated as follows:

$$L_{\max} = (240 - R_{\text{device}}) / (\text{Resistance per Foot of Desired Wire})$$

Terminals

Input 1	3, 17
Input 2	4, 17
Input 3	5, 17
Input 4	6, 17
Input 5	7, 17
Input 6	8, 17
Input 7	9, 17

Engine System Inputs

Stated accuracies are subject to the accuracy of the senders used. Values within these ranges are deemed “good” and the DGC-2020ES will use them for the appropriate calculation and protection. Values outside these ranges are deemed “bad” and the DGC-2020ES will begin timing towards a sender failure condition.

Fuel Level Sensing

Resistance Range	5 to 250 Ω nominal
Terminals	1, 2 (sender common)
Accuracy	$\pm 1.3 \Omega$ or $\pm 2.1\%$ of actual resistance

Coolant Temperature Sensing

Resistance Range	5 to 2,750 Ω nominal
Terminals	53, 2 (sender common)
Accuracy	$\pm 6 \Omega$ or $\pm 2.4\%$ of actual resistance

Oil Pressure Sensing

Resistance Range	5 to 250 Ω nominal
Terminals.....	52, 2 (sender common)
Accuracy.....	$\pm 1.4 \Omega$ or $\pm 2.3\%$ of actual resistance

Engine Speed Sensing

Magnetic Pickup

Voltage Range	3 to 35 V peak (6 to 70 V peak-peak)
Frequency Range.....	32 to 10,000 Hz
Terminals.....	32 (+), 31 (-)

Generator Voltage

Range.....	12 to 576 V rms
Terminals.....	45 (A-phase)
	43 (B-phase)
	41 (C-phase)

Output Contacts

Start, Run, and Prestart Relays

Rating	5 A, 28 Vdc—general purpose, 1.2 A pilot duty, the load must be in parallel with a diode rated at least 3 times the coil current and 3 times the coil voltage.
--------------	--

Terminals

START.....	19, 20
RUN.....	21, 22
PRE	23, 24

Programmable Relays (4)

Rating	2 A, 28 Vdc—general purpose, 1.2 A pilot duty, the load must be in parallel with a diode rated at least 3 times the coil current and 3 times the coil voltage.
--------------	--

Terminals

Output 1.....	26, 25 (common)
Output 2.....	27, 25 (common)
Output 3.....	29, 28 (common)
Output 4.....	30, 28 (common)

The programmable relays share common terminals: terminal 25 is used for outputs 1 and 2, terminal 28 is used for outputs 3 and 4.

Metering

Generator and Bus Voltage (rms)

Metering Range.....	0 to 576 Vac (direct measurement)
	577 to 99,999 Vac (through VT using VT ratio setting)
VT Ratio Range.....	1:1 to 125:1 in primary increments of 1
Accuracy*	$\pm 3.0\%$ of programmed rated voltage or ± 3 Vac
Display Resolution	1 Vac

* Voltage metering indicates 0 V when generator voltage is below 2% of the full-scale rating.

Generator Current (rms)

Generator current is measured at the secondary windings of user-supplied 1 A or 5 A CTs.

Metering Range.....	0 to 5,000 Aac
CT Primary Range	1 to 5,000 Aac in primary increments of 1 Aac
Accuracy*.....	$\pm 3.0\%$ of programmed rated current or ± 3 Aac
Display Resolution	1 Aac

* Current metering indicates 0 A when generator current is below 2% of the full-scale rating.

Generator and Bus Frequency

Frequency is sensed through the generator and bus voltage inputs (phases A and B).

Metering Range.....	10 to 72 Hz
Accuracy.....	$\pm 0.25\%$ or 0.05 Hz
Display Resolution	0.1 Hz

Apparent Power

Indicates total kVA and individual line kVA (4-wire, line-to-neutral or 3-wire, line-to-line).

Measurement/Calculation Methods

Total	$kVA = (V_{L-L} \times I_L \times \sqrt{3}) \div 1000$
4-Wire, Line-to-Neutral	kVA calculated with respect to neutral
3-Wire, Line-to-Line.....	A-phase kVA = $V_{AB} \times I_A \div 1000 \div \sqrt{3}$ B-phase kVA = $V_{BC} \times I_B \div 1000 \div \sqrt{3}$ C-phase kVA = $V_{CA} \times I_C \div 1000 \div \sqrt{3}$
Accuracy.....	$\pm 5\%$ of the full-scale indication or ± 6 kVA *

* Applies when temperature is between -40°C to $+70^{\circ}\text{C}$. KVA metering indicates 0 kVA when the generator kVA is below 2% of the full-scale rating.

Power Factor

Metering Range.....	0.2 leading to 0.2 lagging
Calculation Method	PF = cosine of the angle between phase AB voltage (V_{ab}) and phase A current (I_a) *
Accuracy.....	± 0.02 †

* In single-phase AC-connected machines, it is the cosine of the angle between phase CA voltage (V_{ca}) and phase C current (I_c).

† Applies when temperature is between -40°C to $+70^{\circ}\text{C}$ (-40°F to $+158^{\circ}\text{F}$).

Note

For the DGC-2020ES to correctly meter power factor, the generator must be rotating in the same phase sequence as dictated by the generator phase rotation setting.

Real Power

Indicates total kW and individual line kW (4-wire, line-to-neutral or 3-wire line-to-line)

Measurement/Calculation Methods

Total	PF \times Total kVA
4-Wire, Line-to-Neutral.....	kW calculated with respect to neutral

3-Wire, Line-to-Line..... $A\text{-phase kW} = V_{AB} \times I_A \times PF \div 1000 \div \sqrt{3}$
 $B\text{-phase kW} = V_{BC} \times I_B \times PF \div 1000 \div \sqrt{3}$
 $C\text{-phase kW} = V_{CA} \times I_C \times PF \div 1000 \div \sqrt{3}$

Accuracy..... $\pm 5\%$ of the full-scale indication or ± 4 kW *

* Applies when temperature is between -40°C to $+70^\circ\text{C}$. KW metering indicates 0 kW when the generator kW is below 2% of the full-scale rating.

Oil Pressure

Metering Range..... 0 to 150 psi, 0 to 10.3 bar, or 0 to 1,034 kPa
 Sensing Resistance Range..... 5 to 250 Ω nominal
 Sensing Accuracy ± 1.4 Ω or $\pm 2.3\%$ of actual resistance
 Display Resolution 1 psi, 0.1 bar, or 1 kPa

Coolant Temperature

Metering Range..... 32 to 410 $^\circ\text{F}$ or 0 to 204 $^\circ\text{C}$
 Sensing Resistance Range..... 5 to 2,750 Ω nominal
 Sensing Accuracy ± 6 Ω or $\pm 2.4\%$ of actual resistance

Battery Voltage

Metering Range..... 6 to 32 Vdc
 Accuracy..... $\pm 3\%$ of actual indication or ± 0.2 Vdc
 Display Resolution 0.1 Vdc

Engine RPM

Metering Range..... 0 to 4,500 rpm
 Accuracy*..... $\pm 2\%$ of actual indication or ± 2 rpm
 Display Resolution 2 rpm

* When engine speed is below 2% of full-scale, reported rpm is 0.

Engine Run Time

Engine run time is retained in nonvolatile memory.

Metering Range..... 0 to 99,999 hours
 Update Interval..... 6 min
 Accuracy..... $\pm 1\%$ of actual indication or ± 12 min
 Display Resolution 1 minute

Maintenance Timer

Maintenance timer indicates the time remaining until genset service is due. Value is retained in nonvolatile memory.

Metering Range..... 0 to 5,000 hours
 Update Interval..... 6 min
 Accuracy..... $\pm 1\%$ or actual indication or ± 12 min
 Display Resolution 1 minute

Fuel Level

Metering Range..... 0 to 100%
 Sensing Resistance Range..... 5 to 250 Ω nominal
 Sensing Accuracy ± 1.3 Ω or $\pm 2.1\%$ of actual resistance
 Display Resolution 1.0%

Generator Protection Functions

Overvoltage (59) and Undervoltage (27)

Pickup Range	70 to 1,000 Vac
Pickup Increment	1 Vac
Inhibit Frequency Range	20 to 66 Hz (27 function only)
Activation Delay Range	0 to 30 s
Activation Delay Increment	0.1 s

Note
The maximum voltage that can be safely applied to the DGC-2020ES is 576 V. The pickup range is higher so that when the low-line override is used, and the scale factor is 0.5 or less, effective protection levels of 500 V can be reached with a scale factor of 0.5.

Underfrequency (81U) and Overfrequency (81O)

Pickup Range	45 to 66 Hz
Pickup Increment	0.1 Hz
Activation Delay Range	0 to 30 s
Activation Delay Increment	0.1 s
Inhibit Voltage Range	70 to 576 Vac (81U function only)

Overcurrent (50)

Pickup Range	0.18 to 1.18 Aac (1 A current sensing)
	0.9 to 7.75 Aac (5 A current sensing)
Time Dial Range	0 to 7,200 s (fixed time curve)
Time Dial Increment	0.1

Phase Imbalance (47)

Pickup Range	5 to 100 Vac
Pickup Increment	1 Vac
Activation Delay Range	0 to 30 s
Activation Delay Increment	0.1 s

Logic Timers

Hours Setting Range	0 to 250
Hours Setting Increment	1
Minutes Setting Range	0 to 250
Minutes Setting Increment	1
Seconds Setting Range	0 to 1,800
Seconds Setting Increment	0.1
Accuracy	±15 ms

Communication Interface

USB

Specification Compatibility	USB 2.0
Data Transfer Speed	115,200 baud
Connector Type	Mini-B jack

RDP-110

Minimum Wire Size	20 AWG
-------------------------	--------

Maximum Wire Length 4,000 feet (1,219 meters)
 Terminals..... 11 (RDP TxD+), 10 (RDP TxD–)

CAN

Differential Bus Voltage..... 1.5 to 3 Vdc
 Maximum Voltage –32 to +32 Vdc with respect to negative battery terminal
 Communication Rate..... 250 kb/s
 Terminals..... 14 (low), 13 (high), and 15 (shield)

Notes

1. If the DGC-2020ES is providing one end of the J1939 bus, a 120 ohm, ½ watt terminating resistor should be installed across terminals 14 (CANL) and 13 (CANH).
2. If the DGC-2020ES is not providing one end of the J1939 bus, the stub connecting the DGC-2020ES to the bus should not exceed 914 mm (3 ft) in length.
3. The maximum bus length, not including stubs, is 40 m (131 ft).
4. The J1939 drain (shield) should be grounded at one point only. If grounded elsewhere, do not connect the drain to the DGC-2020ES.

Real-Time Clock

Clock has leap year and selectable daylight saving time correction. Backup capacitor and backup battery sustain timekeeping during losses of DGC-2020ES control power.

Resolution 1 s
 Accuracy..... ±1.73 s/d at 25°C

Clock Holdup

Capacitor Holdup Time Up to 24 hours depending on conditions
 Battery Holdup Time Approximately 10 years depending on conditions

Liquid Crystal Display (LCD)

Display 128 by 64 dot pixels LCD with LED Backlight
 Operating Temperature..... –40 to +70°C (–40 to +158°F)
 Storage Temperature..... –40 to +80°C (–40 to +176°F)

LCD Heater

The ambient temperature is monitored by a temperature sensor located near the LCD inside the DGC-2020ES. The LCD heater turns on when the ambient temperature falls below 0°C (32°F). The heater turns off when the ambient temperature rises above 5°C (41°F). This range of operation implements 5°C (9°F) of hysteresis between when the heater turns on and turns off.

Type Tests

Shock and Vibration EN60068-2-6
 Dielectric Strength..... IEC 255-5
 Impulse EN60664-1
 Transients..... EN61000-4-4
 Static Discharge EN61000-4-2

Shock

Withstands 15 G in three perpendicular planes.

Vibration

Tested in three mutually perpendicular planes for 8 hours over the following ranges:
 3 to 25 Hz at 0.063 inches (1.6 mm), peak amplitude
 25 to 2,000 Hz at 5G

Radio Interference

Type tested using a 5 W, hand-held transceiver operating at random frequencies centered around 144 and 440 MHz with the antenna located within 150 mm (6") of the device in both vertical and horizontal planes.

HALT (Highly Accelerated Life Testing)

HALT is used by Basler Electric to prove that our products will provide the user with many years of reliable service. HALT subjects the device to extremes in temperature, shock, and vibration to simulate years of operation, but in a much shorter period span. HALT allows Basler Electric to evaluate all possible design elements that will add to the life of this device. As an example of some of the extreme testing conditions, the DGC-2020ES was subjected to temperature tests (tested over a temperature range of -100°C to $+130^{\circ}\text{C}$), vibration tests (of 5 to 50 G at $+20^{\circ}\text{C}$), and temperature/vibration tests (tested at 50 G over a temperature range of -95°C to $+125^{\circ}\text{C}$). Combined temperature and vibration testing at these extremes proves that the DGC-2020ES is expected to provide long-term operation in a rugged environment. Note that the vibration and temperature extremes listed in this paragraph are specific to HALT and do not reflect recommended operation levels.

Ignition System

Tested in close proximity to an unshielded, unsuppressed Altronic DISN 800 Ignition System.

Environment

Operating Temperature	-40 to $+158^{\circ}\text{F}$ (-40 to $+70^{\circ}\text{C}$)
Storage Temperature	-40 to $+185^{\circ}\text{F}$ (-40 to $+85^{\circ}\text{C}$)
Humidity	IEC 68-2-38
Salt Spray	IEC 68-2-52
Ingress Protection	IEC IP56 for front panel

UL Approval

The DGC-2020ES is a Recognized Component applicable to the Canadian and US safety standards and requirements by UL. The product is covered under UL File (E97035 FTPM2/FTPM8) and evaluated to the following standards through UL:

- UL6200
- CSA C22.2 No. 14

CE and UKCA Compliance

This product has been evaluated and complies with the requirements set forth by the EU legislation and UK Parliament:

- Low Voltage Directive (LVD) - 2014/35/EU
- Electromagnetic Compatibility (EMC) - 2014/30/EU
- Hazardous Substances (ROHS2) -2011/65/EU

Harmonized Standards used for evaluation:

- EN 50178 - *Electronic Equipment for use in Power Installations*
- EN 61000-6-4 - *Electromagnetic Compatibility (EMC), Generic Standards, Emission Standard for Industrial Environments*
- EN 61000-6-2 - *Electromagnetic Compatibility (EMC), Generic Standards, Immunity for Industrial Environments*
- EN 50581 – *Technical Documentation for the Assessment of Electrical and Electric Products with Respect to the Restriction of Hazardous Substances (ROHS2)*

NFPA Compliance

Designed to comply with NFPA Standard 110, *Standard for Emergency and Standby Power*.

EAC Mark (Eurasian Conformity)

For current certificate, see www.basler.com.

China RoHS

The following table serves as the declaration of hazardous substances for China in accordance with PRC standard SJ/T 11364-2014. The EFUP (Environment Friendly Use Period) for this product is 40 years.

PRODUCT:		9469200XXX				
零件名称 Part Name	有害物质 Hazardous Substances					
	铅 Lead (Pb)	汞 Mercury (Hg)	镉 Cadmium (Cd)	六价铬 Hexavalent Chromium (Cr ⁶⁺)	多溴联苯 Polybrominated Biphenyls (PBB)	多溴二苯醚 Polybrominated Diphenyl Ethers (PBDE)
金属零件 Metal parts	○	○	○	○	○	○
聚合物 Polymers	○	○	○	○	○	○
电子产品 Electronics	X	○	○	○	○	○
电缆和互连配件 Cables & interconnect accessories	○	○	○	○	○	○
绝缘材料 Insulation material	○	○	○	○	○	○

本表格依据 SJ/T11364 的规定编制。

O: 表示该有害物质在该部件所有均质材料中的含量均在 GB/T 26572 规定的限量要求以下。

X: 表示该有害物质至少在该部件的某一均质材料中的含量超出 GB/T 26572 规定的限量要求。

This form was prepared according to the provisions of standard SJ/T11364.

O: Indicates that the hazardous substance content in all homogenous materials of this part is below the limit specified in standard GB/T 26572.

X: Indicates that the hazardous substance content in at least one of the homogenous materials of this part exceeds the limit specified in standard GB/T 26572.

Physical

Weight 1.9 lb (0.86 kg)
Dimensions..... See the *Mounting* chapter.

8 • Maintenance

Preventive maintenance consists of periodically checking that the connections between the DGC-2020ES and the system are clean and tight. Periodically check that the mounting hardware is clean and fastened with the proper amount of torque. DGC-2020ES units are manufactured using state-of-the-art, surface-mount technology. These components are encased in potting material. As such, Basler Electric recommends that no repair procedures be attempted by anyone other than Basler Electric personnel.

Storage

This device contains long-life aluminum electrolytic capacitors. For devices that are not in service (spares in storage), the life of these capacitors can be maximized by energizing the device for 30 minutes once per year.

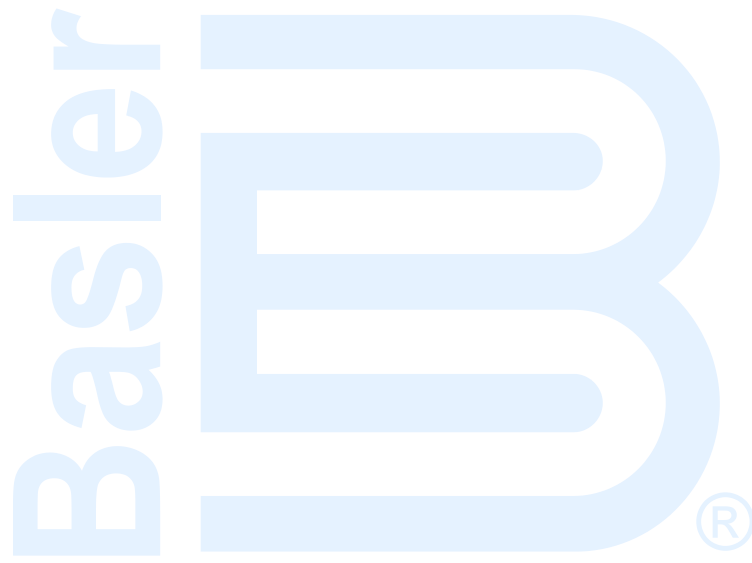

9 • Troubleshooting

If you do not get the results that you expect from the DGC-2020ES, first check the programmable settings for the appropriate function. Use the following troubleshooting procedures when difficulties are encountered in the operation of your genset control system.

Communications

USB Port Does Not Operate Properly

Step 1. Verify that the proper port of your computer is being used. For more information, refer to the *Communication* chapter in the *Configuration* manual.

CAN Communication Does Not Operate Properly

- Step 1: Verify that there is a 120-ohm termination resistor on each end of the bus section of the wiring, and that there are not any termination resistors at any node connections that are on stubs from the main bus.
- Step 2: Check all CAN wiring for loose connections and verify that the CAN H and CAN L wires have not gotten switched somewhere on the network.
- Step 3: Verify that the cable length of the bus section of the wiring does not exceed 40 meters (131 feet), and verify that any stubs from the main bus do not exceed 3 meters (9.8 feet) in length.
- Step 4: If the engine is equipped with a Volvo or *mtu* ECU, verify that the ECU Configuration setting is set to match the actual ECU configuration.

Inputs and Outputs

Programmable Inputs Do Not Operate as Expected

- Step 1. Verify that all wiring is properly connected. Refer to the *Typical Connections* chapter.
- Step 2. Confirm that the inputs are programmed properly.
- Step 3. Ensure that the input at the DGC-2020ES is actually connected to the BATT– terminal (17).

Programmable Outputs Do Not Operate as Expected

- Step 1. Verify that all wiring is properly connected. Refer to the *Typical Connections* chapter.
- Step 2. Confirm that the outputs are programmed properly.

Metering/Display

Incorrect Display of Battery Voltage, Coolant Temperature, Oil Pressure, or Fuel Level

- Step 1. Verify that all wiring is properly connected. Refer to the *Typical Connections* chapter.
- Step 2. Confirm that the SENDER COM terminal (2) is connected to the negative battery terminal and the engine-block side of the senders. Current from other devices sharing this connection can cause erroneous readings.
- Step 3. If the displayed battery voltage is incorrect, ensure that the proper voltage is present between the BATT+ terminal (18) and the SENDER COM terminal (2).
- Step 4. Verify that the correct senders are being used.
- Step 5. Use a voltmeter connected between the BATT– terminal (17) and the SENDER COM terminal (2) on the DGC-2020ES to verify that there is no voltage difference at any time. Any voltage

differences may manifest themselves as erratic sender readings. Wiring should be corrected so that no differences exist.

- Step 6: Check the sender wiring and isolate sender wiring from any of the ac wiring in the system. The sender wiring should be located away from any power ac wiring from the generator and any ignition wiring. Separate conduits should be used for sender wiring and any ac wiring.

Incorrect Display of Generator Voltage

- Step 1. Verify that all wiring is properly connected. Refer to the *Typical Connections* chapter.
- Step 2. Ensure that the proper voltage is present at the DGC-2020ES voltage sensing inputs (40, 41, 43, and 45).
- Step 3. Verify that the voltage transformer ratio and sensing configuration is correct.
- Step 4. Confirm that the voltage sensing transformers are correct and properly installed.

Incorrect Measurement or Display of Generator Current

- Step 1. Verify that all wiring is properly connected. Refer to the *Typical Connections* chapter.
- Step 2. Ensure that the proper current is present at the DGC-2020ES current sensing inputs 33, 34, 35, 36, 37, and 38.
- Step 3. Verify that the current sensing transformer ratios are correct.
- Step 4. Confirm that the current sensing transformers are correct and properly installed.

Incorrect Display of Engine RPM

- Step 1. Verify that all wiring is properly connected. Refer to the *Typical Connections* chapter.
- Step 2. Verify that the flywheel teeth setting is correct.
- Step 3. Verify that the prime mover governor is operating properly.
- Step 4. Verify that the measured frequency of the voltage at the MPU input (31 and 32) is correct.
- Step 5. If the MPU is shared with the governor, verify that the polarity of the MPU input to the governor matches the polarity of the MPU input to the DGC-2020ES.

DGC-2020ES Indicates Incorrect Power Factor

Check the rotation of the machine and the labeling of the A-B-C terminals. The machine must be rotating in the same phase sequence as dictated by the generator phase rotation setting for correct power factor metering. A power factor indication of 0.5 with resistive load present is a symptom of incorrect phase rotation.

LCD is Blank and all LEDs are Flashing at Approximately Two-Second Intervals

This indicates that the DGC-2020ES does not detect that valid application firmware is installed. The unit is running its boot loader program, waiting to accept a firmware upload.

- Step 1. Start *BESTCOMSPlus*[®]. Use the top pull-down menu and select FILE > NEW > DGC-2020ES.
- Step 2. Select COMMUNICATIONS > UPLOAD DEVICE FILES and select the device package file that contains the firmware and language you want to upload.
- Step 3. Check the boxes for DGC-2020ES Firmware and DGC-2020ES Language Module. Click the UPLOAD button to start the upload process.

Ground Faults Detected in Ungrounded System Applications

- Step 1: Verify that there is no connection from the neutral connection of the generator to the system ground.

- Step 2: Perform insulation resistance tests on the system wiring to check for insulation integrity in the overall system.
- Step 3: If ground faults are detected on a DGC-2020ES in an ungrounded system application, it is recommended that potential transformers be employed on the voltage sensing inputs to provide full isolation between the DGC-2020ES and monitored voltage phases.
- Step 4: If potential transformers are in place, remove the connectors from the DGC-2020ES one at a time. If removal of a connector removes the ground fault, check the system wiring to that connector and out into the system to verify that connections are secure and all wiring insulation is in good condition.

Generator Breaker and Mains Breaker

Generator Breaker Will Not Close to a Dead Bus

- Step 1: Review the description of how the generator breaker logic element functions contained in the GENBRK logic element description in the BESTlogic™ *Plus* chapter in the *Configuration* manual.
- Step 2: Review the section on breaker close requests in the *Breaker Management* chapter in the *Configuration* manual.
- Step 3: Navigate to the SETTINGS > BREAKER MANAGEMENT > BREAKER HARDWARE > GEN BREAKER screen and set DEAD BUS CL ENBL to ENABLE.
- Step 4: Verify that the Generator status is stable. The breaker will not close if the generator status is not stable. Check status by using the Metering Explorer in BESTCOMS*Plus* and verify that when the generator is running, the GEN STABLE status LED is lit. If necessary, modify the settings on the SETTINGS > BREAKER MANAGEMENT > BUS CONDITION DETECTION screen.
- Step 5: Verify the bus status is DEAD. Check status by using the Metering Explorer in BESTCOMS*Plus* and verify that when the generator is running, the BUS DEAD status LED is lit. If necessary, modify the settings on the SETTINGS > BREAKER MANAGEMENT > BUS CONDITION DETECTION screen.
- Step 6: Verify the connections in BESTlogic*Plus* Programmable Logic to the generator breaker logic element. The *Status* input must be driven by an “A” or normally open contact from the generator breaker. The OPEN and CLOSE command inputs on the left side of the logic block are inputs for open and close commands. These can be wired to physical inputs if it is desired to have open and close command switches. If they are wired, they must either be pulsed inputs, or some logic must be employed so that the open and close command inputs are never driven at the same time. If these are both driven at the same time, the breaker is receiving open and close commands simultaneously. The breaker will not change state if it is being commanded to open and close at the same time.
- Step 7: Verify the breaker is receiving a close command. Breaker close command sources are:
- The DGC-2020ES itself when the automatic mains fail transfer (ATS) feature is enabled.
 - The DGC-2020ES itself when the RUN WITH LOAD logic element receives a *Start* pulse in the programmable logic.
 - The DGC-2020ES itself when started from the Exercise Timer and the Run with Load box is checked in the Generator Exerciser settings.
 - Manual Breaker Close Input Contacts applied to the Open and Close inputs on the left side of the Generator Breaker logic element in the programmable logic.
- Step 8: Verify the wiring to the breaker from the DGC-2020ES. If it seems OK, you can do a manual close and open by modifying the programmable logic. Map some unused outputs to the OPEN and CLOSE outputs from the Gen Breaker Block in the programmable logic. Map a virtual switch to the logic output that would normally be the breaker open output. Map another virtual switch to the logic output that would normally be the breaker close output. Connect with BESTCOMS*Plus*, and exercise the virtual switches using the Control panel located in the

Metering Explorer. Never turn open and close on at the same time. This could damage the breaker and/or motor operator. If everything is working as expected, restore the logic to its original diagram.

Generator Breaker Does Not Open When It Should

- Step 1: Review the description of how the generator breaker logic element functions contained in the GENBRK logic element description in the *BESTlogicPlus* chapter in the *Configuration* manual.
- Step 2: Review the section on breaker operation requests in the *Breaker Management* chapter in the *Configuration* manual.
- Step 3: Verify the connections in BESTLogicPlus Programmable Logic to the generator breaker logic element. The *Status* input must be driven by an “A” or normally open contact from the generator breaker. The OPEN and CLOSE command inputs on the left side of the logic block are inputs for open and close commands. These can be wired to physical inputs if it is desired to have open and close command switches. If they are wired, they must either be pulsed inputs, or some logic must be employed so that the open and close command inputs are never driven at the same time. If these are both driven at the same time, the breaker is receiving open and close commands simultaneously. The breaker will not change state if it is being commanded to open and close at the same time.
- Step 4: Verify the breaker is receiving an open command. Breaker open command sources are:
- The DGC-2020ES itself when the automatic transfer (ATS) feature is enabled.
 - The DGC-2020ES itself when the RUN WITH LOAD logic element receives a *Stop* pulse in the programmable logic.
 - The DGC-2020ES itself when shutting down the engine due to an active alarm.
 - The DGC-2020ES itself when ending a run session from the Exercise Timer and the *Run with Load* box is checked in the Generator Exerciser settings.
 - Manual Breaker Open Input Contacts applied to the Open and Close inputs on the left side of the Generator Breaker logic element in the programmable logic.
- Step 5: Verify the wiring to the breaker from the DGC-2020ES. If it seems OK, you can do a manual close and open by modifying the programmable logic. Map some unused outputs to the OPEN and CLOSE outputs from the Gen Breaker Block in the programmable logic. Map a virtual switch to the logic output that would normally be the breaker open output. Map another virtual switch to the logic output that would normally be the breaker close output. Connect with BESTCOMSPlus, and exercise the virtual switches using the Control panel located in the Metering Explorer. Never turn open and close on at the same time. This could damage the breaker and/or motor operator. If everything is working as expected, restore the logic to its original diagram.

Mains Breaker Does Not Open When Mains Fails

- Step 1: Verify that a Mains Breaker has been configured by examining the settings on the SETTINGS > BREAKER MANAGEMENT > BREAKER HARDWARE screen.
- Step 2: Verify the mains breaker has been correctly included in the programmable logic.
- Step 3: Verify that the MAINS FAIL TRANSFER parameter is set to ENABLE on the SETTINGS > BREAKER MANAGEMENT > BREAKER HARDWARE screen.
- Step 4: Verify that a failure of the mains is detected by the DGC-2020ES. Check status using the Metering Explorer in BESTCOMSPlus and verify that the MAINS FAIL status LED is lit when the power on the DGC-2020ES bus voltage input is either out of voltage or frequency range. If necessary, modify the settings on the SETTINGS > BREAKER MANAGEMENT > BUS CONDITION DETECTION screen to achieve correct detection.
- Step 5: Verify the wiring to the breaker from the DGC-2020ES. If it seems OK, you can do a manual close and open by modifying the programmable logic. Map some unused outputs to the OPEN

and CLOSE outputs from the Gen Breaker Block in the programmable logic. Map a virtual switch to the logic output that would normally be the breaker close output. Map another virtual switch to the logic output that would normally be the breaker close output. Connect with BESTCOMSP^{Plus}, and exercise the virtual switches using the Control panel located in the Metering Explorer. Never turn open and close on at the same time. This could damage the breaker and/or motor operator. If everything is working as expected, restore the logic to its original diagram.

Mains Breaker Does Not Close After Mains Returns

- Step 1: Verify that a Mains Breaker has been configured by examining the settings on the SETTINGS > BREAKER MANAGEMENT > BREAKER HARDWARE screen.
- Step 2: Verify the mains breaker has been correctly included in the programmable logic.
- Step 3: Verify that the MAINS FAIL TRANSFER parameter is set to ENABLE on the SETTINGS > BREAKER MANAGEMENT > BREAKER HARDWARE screen.
- Step 4: Verify that stable mains power is detected by the DGC-2020ES. Check status using the Metering Explorer in BESTCOMSP^{Plus} and verify that the MAINS STABLE status LED is lit when the power on the DGC-2020ES bus voltage input is good. If necessary, modify the settings on the SETTINGS > BREAKER MANAGEMENT > BUS CONDITION DETECTION screen to achieve correct detection.
- Step 5: Verify the wiring to the breaker from the DGC-2020ES. If it seems OK, you can do a manual close and open by modifying the programmable logic. Map some unused outputs to the OPEN and CLOSE outputs from the Gen Breaker Block in the programmable logic. Map a virtual switch to the logic output that would normally be the breaker open output. Map another virtual switch to the logic output that would normally be the breaker close output. Connect with BESTCOMSP^{Plus}, and exercise the virtual switches using the Control panel located in the Metering Explorer. Never turn open and close on at the same time. This could damage the breaker and/or motor operator. If everything is working as expected, restore the logic to its original diagram.

DGC-2020ES Front Panel Debug Screen

There is one debug screen in the DGC-2020ES that can be useful for debugging I/O module related issues. The following debug screen is available: CEM DEBUG

CEM DEBUG

This screen shows the binary data that is being sent between the CEM-2020 (Contact Expansion Module) and the DGC-2020ES.

The CEM DEBUG screen is located on the front panel at SETTINGS > SYSTEM PARAMS > REMOTE MODULE SETUP > CEM SETUP > CEM DEBUG MENU.

The following parameters are visible on the CEM DEBUG screen:

- DGC TO CEM BP: DGC-2020ES to CEM-2020 Binary Points. This is the status of the CEM-2020 output relays being transmitted from the DGC-2020ES to the CEM-2020. This is a 32-bit, bit packed number representing the desired states of the CEM-2020 outputs. The left most bit is the first output, etc.
- CEM TO DGC BP: CEM-2020 to DGC-2020ES Binary Points. This is the status of the CEM-2020 inputs being transmitted from the CEM-2020 to the DGC-2020ES. This is a 32-bit, bit packed number representing the metered states of the CEM-2020 inputs. The left most bit is the first input, etc.



